

gabbiani p/pt

automatic horizontal beam saws

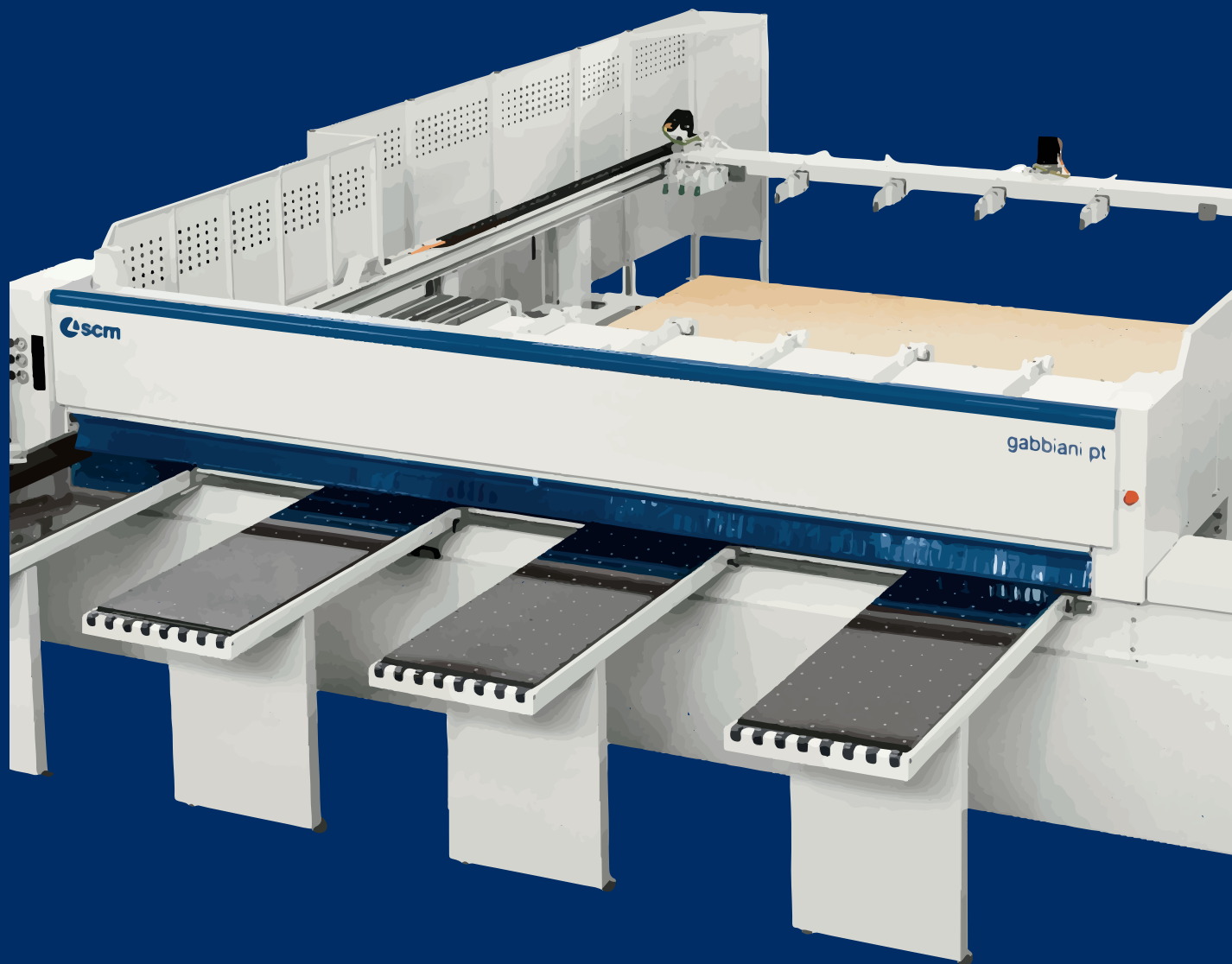



THE PERFECT CUT





gabbiani p/pt
automatic horizontal beam saws

GABBIANI P/PT

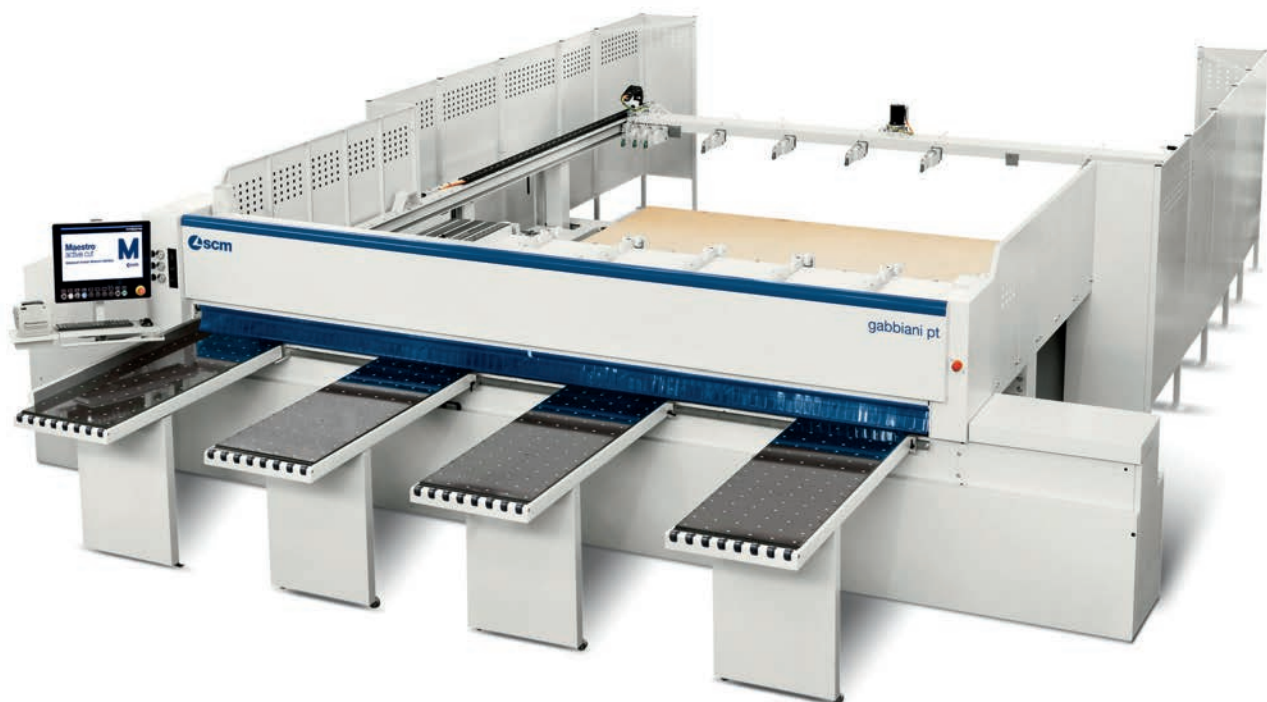

THE BALANCE OF A MACHINE
**EASY, FAST,
FLEXIBLE.**





6

GABBIANI P/PT

FLEXIBILITY

8

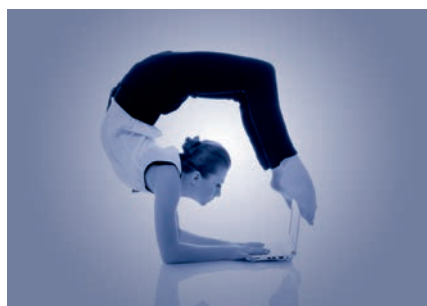

Fast tool setting thanks to the automatism that allow an easy use of the machine and an increase in productivity.

PERFECTION

10



Immediate cuts with the maximum cleanliness of the working table.

VERSATILITY

12



Several machine settings to satisfy every processing requirement with any kind of material.





POWER

16

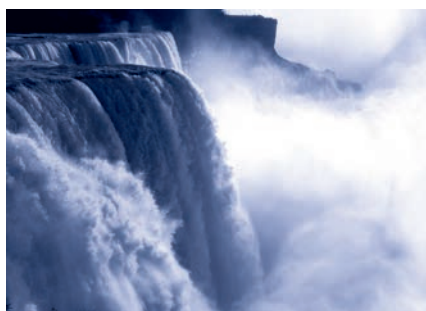

No cutting limit.
No loading limit.
No limit for integration with lines.

SOFTWARE

18



Planning and monitoring of the entire
sizing process, both on board as well as in
the office.

24

Optional accessories

26

Tailor-made solutions

28

Overall dimensions



P/PT

TECHNICAL FEATURES OVERVIEW

TECHNOLOGICAL ADVANTAGES

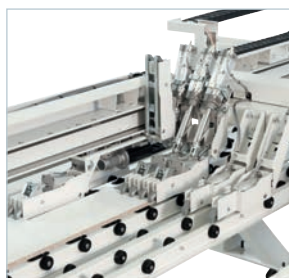

Modular FLEXCUT system
It enables the processing of complex cutting patterns in very rapid cycle times. (opt.)



Overhead side protections: more space for the woodworking workshop
The shape of the protections allows to use the large space under the rear part of the machine as additional storage for panels.



Selectable air blowing table: an essential tool
Possibility to enable/ disable the air blowing feature on each table section via four independent motors. It ensures optimal sliding of the panels only where it is needed and avoids the accidental falling of panels already cut and temporarily stored on the tables.



Automatic side alignment device: the best precision for cross cutting
Device sliding on linear guideways with recirculating ball bearing, always ensuring cut perfection and cycle time reduction.





gabbiani p/pt

automatic horizontal beam saws



Floating clamps: the guarantee of the end result

The special shape of the clamps allows safe grip of panels at the maximum speed and perfect parallelism, even when panels are not perfectly planar.



Loading platform

High customization and maximum versatility according to the user's requirements, with powered roller conveyor with trilateral loading (opt. on gabbiani pt).

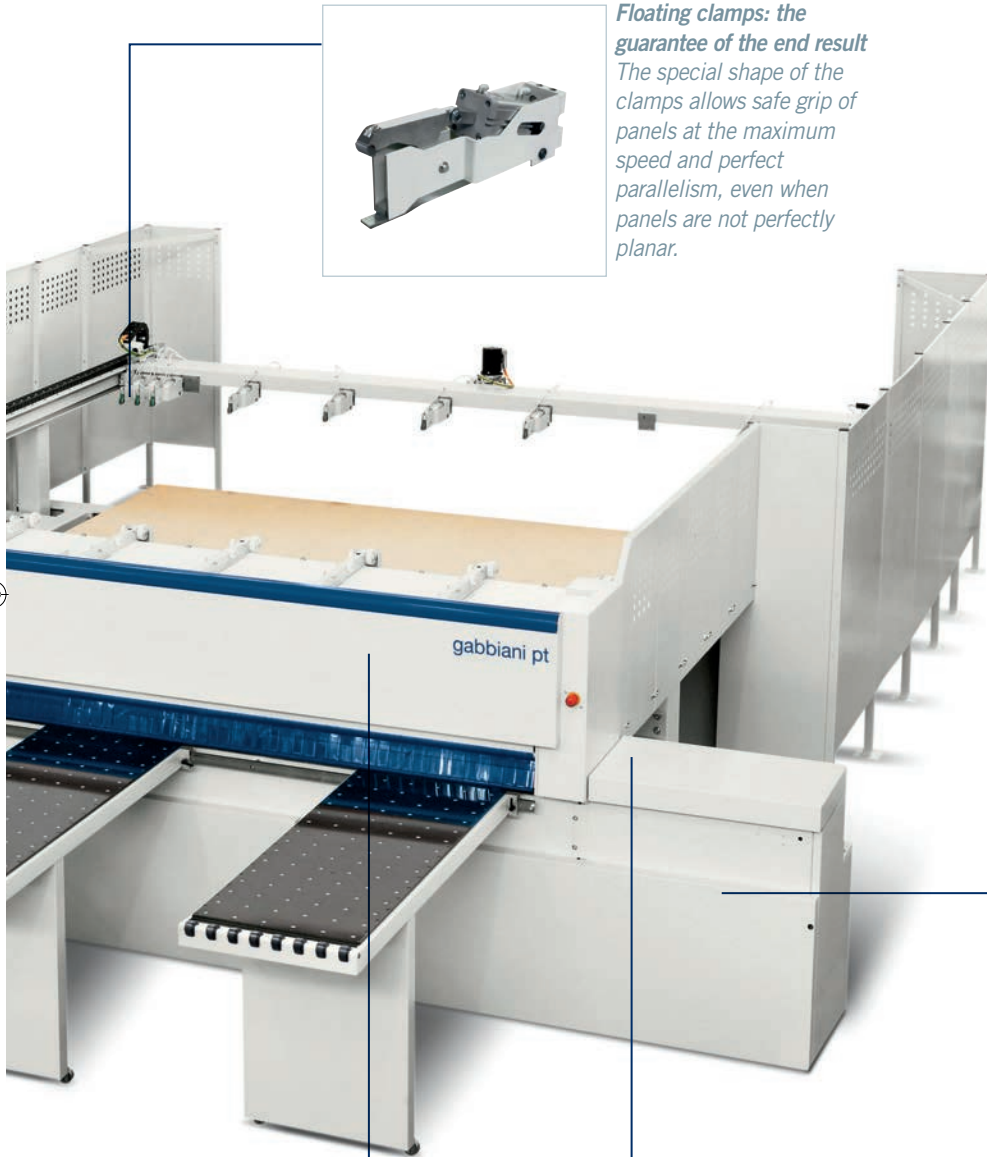

Carriage with independent raising of the main blade and scoring blade (opt.)



Slotted pressure beam: the best answer for cutting requirements

Special openings on the pressure beam eliminate the interference zone with clamps, and greatly reduce the off-cuts.



In a few seconds the "SAW-SET" device carries out fast and precise tools adjustment both on cross and longitudinal cutting axes. (opt.)



PERFECTION AND FLEXIBILITY OF CUT



Parallelism and absolute perpendicularity of the machine base guides, combined with a new saw carriage, always guarantee a perfect cut.



SAW-SET: TOOL CHANGING HAS NEVER BEEN SO EASY

In a few seconds the "SAW-SET" device carries out fast and precise tools adjustment due to the electronic setting, allowing an intuitive use of the machine and a productivity increase (opt).

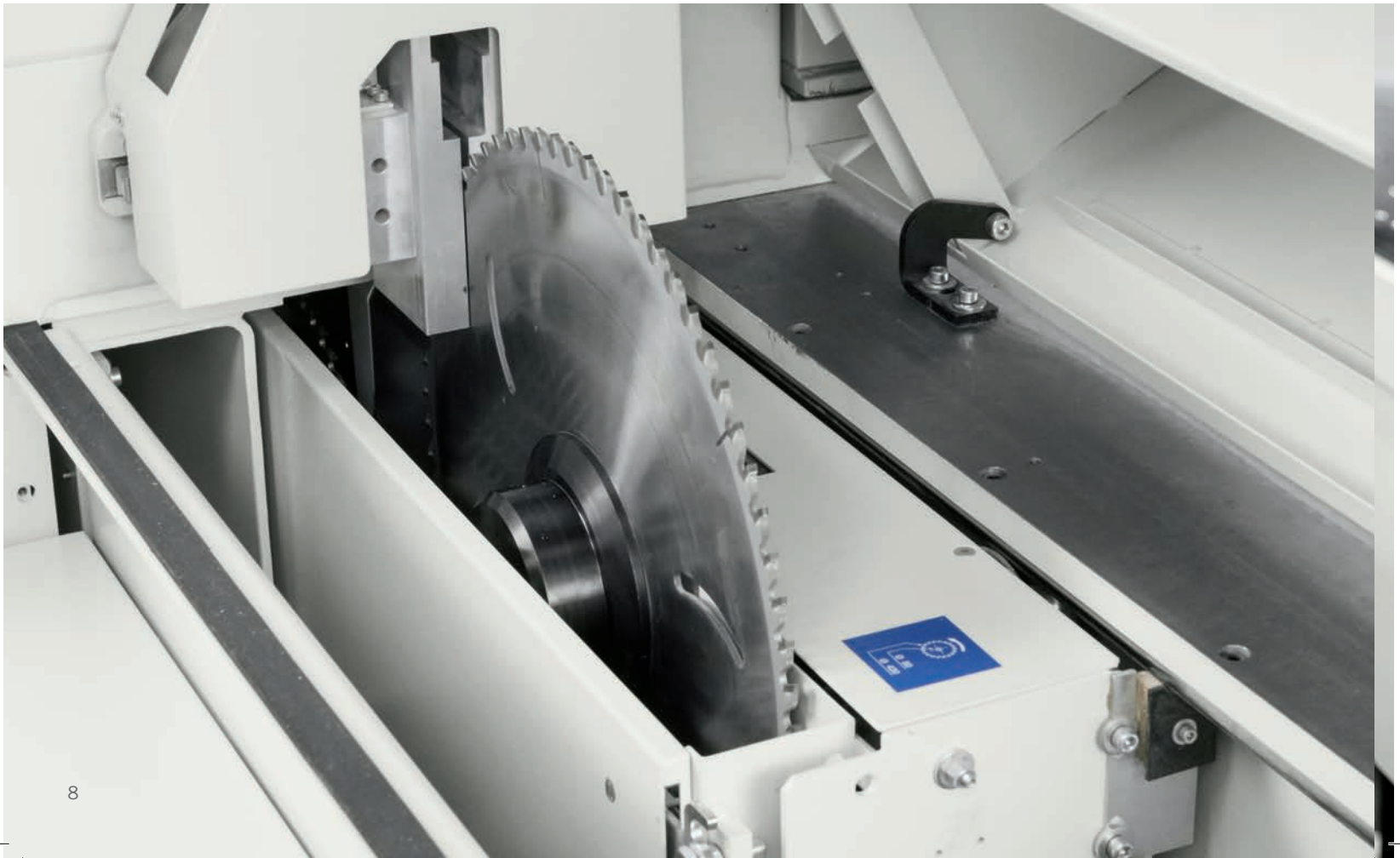



gabbiani p/pt

automatic horizontal beam saws

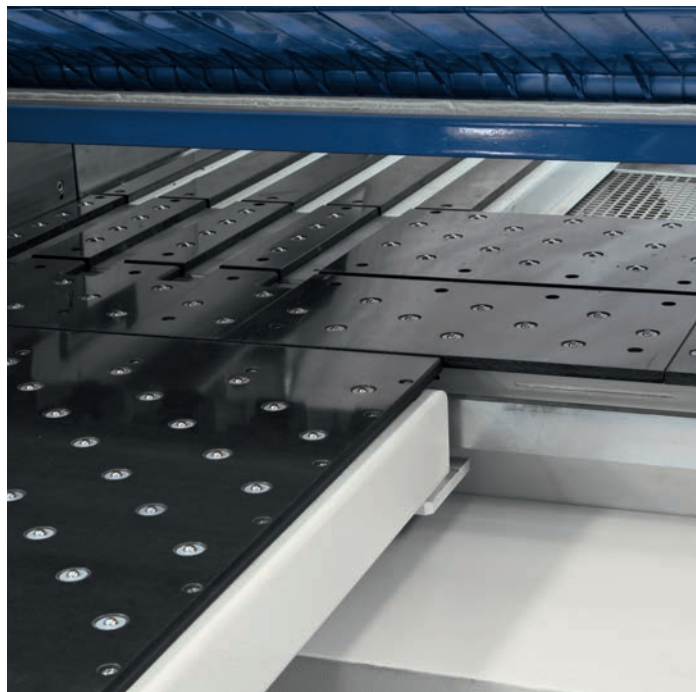

AIR BLOWING: ALSO ON THE MACHINE TABLE

The sliding of heavy or delicate materials is achieved through the air blowing on the cutting table that protects against the risks of friction.



PERFECTION OF CUT

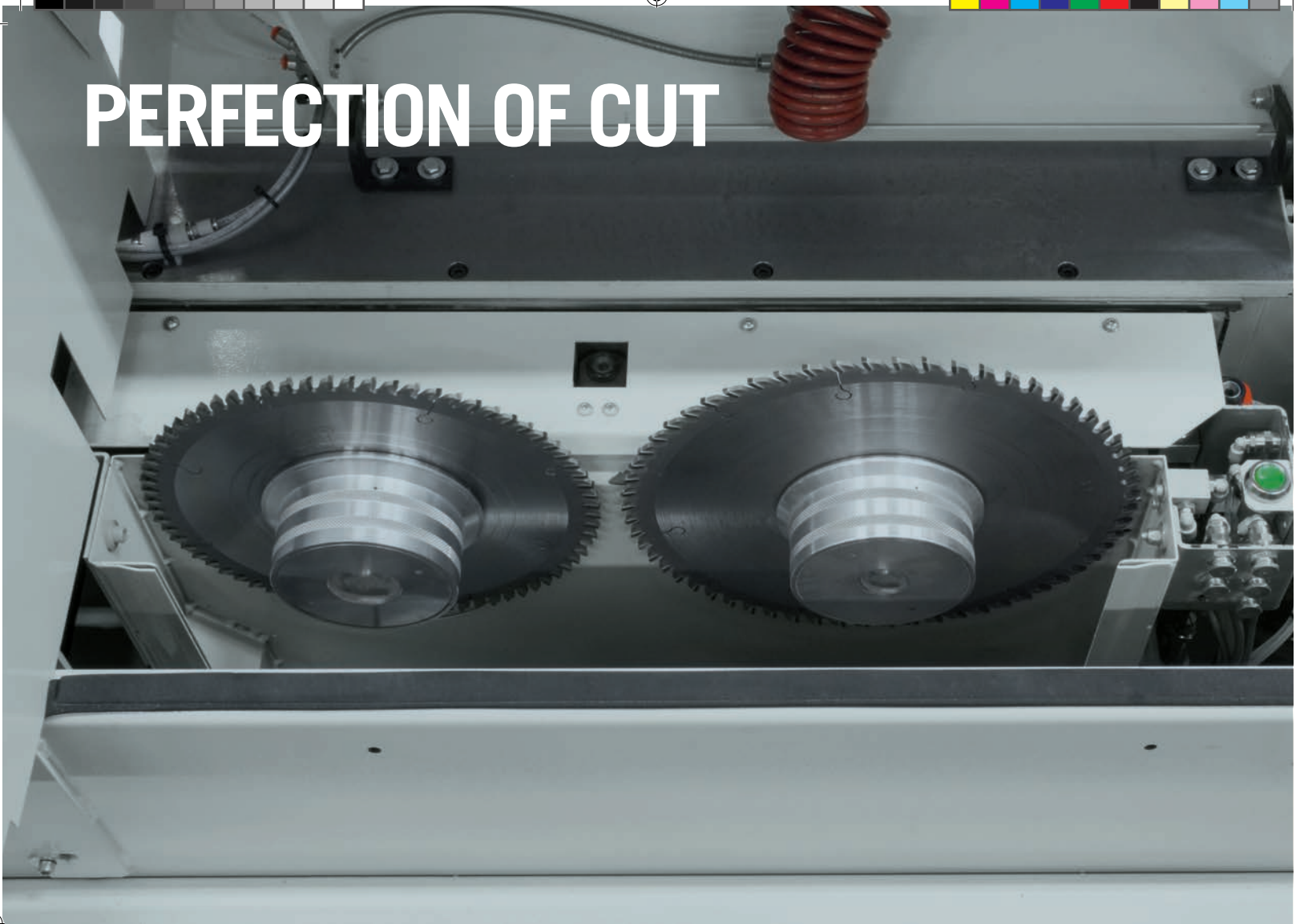

CARRIAGE WITH INDEPENDENT RAISING OF MAIN BLADE AND SCORING BLADE (opt.)

Additional functions available:

- optimised blade stroke
- post-forming
- groove execution
- cuts-out "windows"
- execution of panels de-tensioning cuts
- blade lubrication

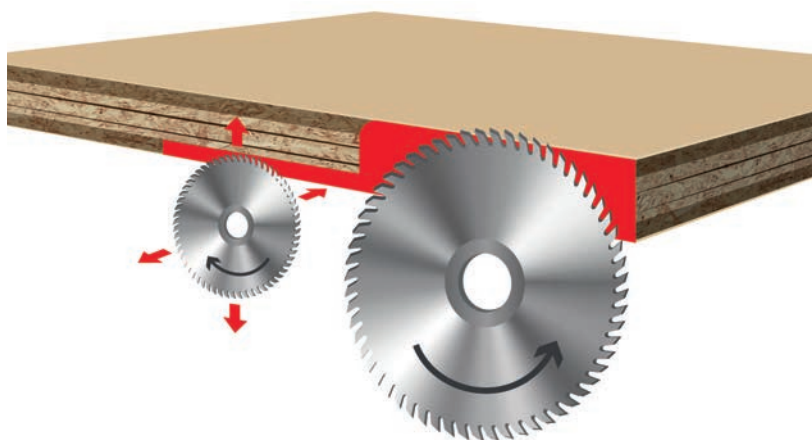

SCORING UNIT ELECTRONIC ADJUSTMENT: TECHNOLOGY FOR REAL SUPPORT

The setting from the PC allows the management of a powered system for the scoring unit automatic positioning, drastically reducing the blade set-up time and avoiding any possible errors. (opt.)



RAPID BLADES LOCKING/UNLOCKING: MACHINING SAFETY IN REDUCED TIME

This system provides safe and constant blade locking and unlocking, due to the pneumatic system which minimizes the standby times for blade changeovers.

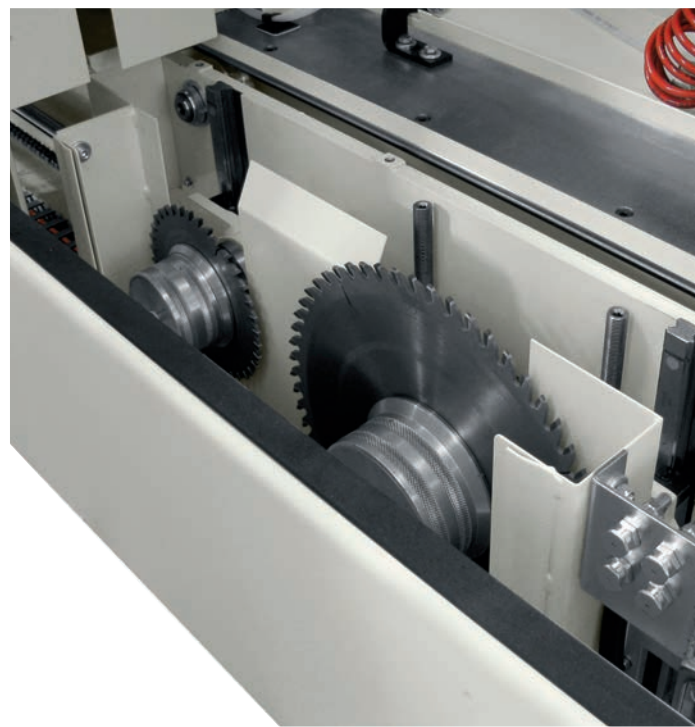

DRIVE BY RACK: FINISH QUALITY AND LONG-LIFE PERFORMANCE

The drive by rack system ensures a smooth and precise movement without necessity of maintenance.



CARRIAGE WITH INDEPENDENT RAISING OF MAGNETIC BAND: A PRECISE CUT IS ALWAYS GUARANTEED

A very high precision pusher even at high-speed due to electronic control positioning (opt.).

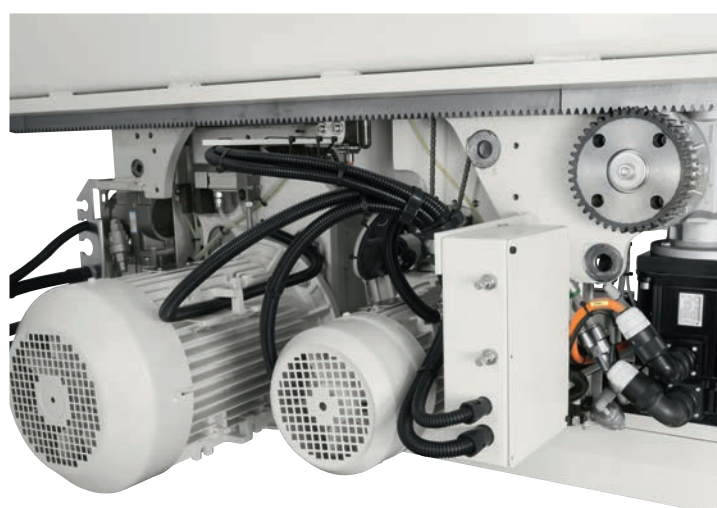

SAW CARRIAGE: GREAT RELIABILITY

Long-life, high-performance and quality due to the use of linear guideways with recirculating ball bearing for the saw carriage unit raising.



MAXIMUM PROCESSING VERSATILITY

INCREASING OF PRODUCTIVITY UP TO 30% AND SPACE SAVING THANKS TO THE SIMULTANEOUS EXECUTION OF BOTH RIP AND CROSS CUTS.

FLEXCUT 1: INCOMPARABLE PRECISION

The use of brushless motors sliding on linear guideway with recirculating ball bearing reduces mechanical parts friction and guarantees best precision.

The extreme flexibility of this device is also ensured by the presence of the main pusher grippers, which can be excluded from the working area, so that strips with different widths can be secured and as a result any type of different cutting can be performed without limiting the stroke (opt.)



From concept



to production



"flexcut application - gabbiani pt" Video



INVERTER: NO COMPROMISE

The possibility to adjust the main blade speed allows a perfect finish with any panel stack height.



OPTIMISED BLADE HEIGHT: FOR SMART CUT

The main blade projection is automatically adjusted according to the panel thickness to be cut. It always guarantees an optimum cut quality and reduces the machine cycle time (opt.).



COOLING AND LUBRICATION OF THE MAIN BLADE

Air-oil mixture sprayed directly on the main blade to reduce friction when cutting and obtaining maximum result on the executed cut (as an option with non-wood materials).



MAXIMUM PROCESSING VERSATILITY



POSTFORMING

Lateral scoring of edged and postformed bars by means of the scoring blade rise (opt.).

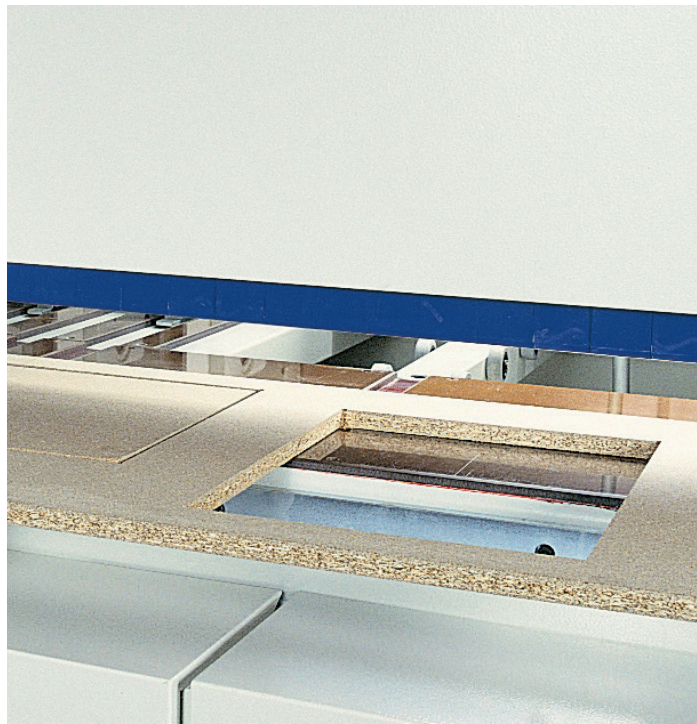

SLOTS EXECUTION DEVICE: AT THE OPERATOR'S SERVICE

This device allows carrying out interrupted cuttings inside the panel to produce slotted doors (opt.).

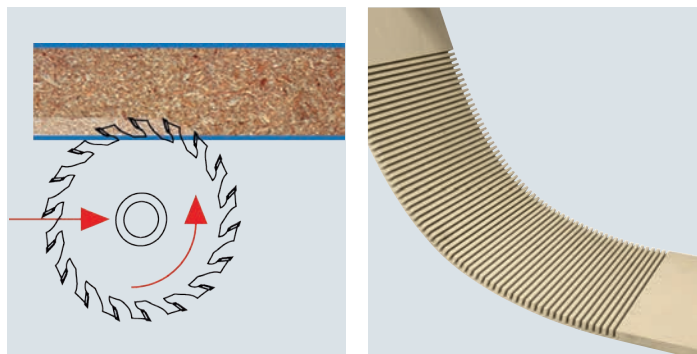
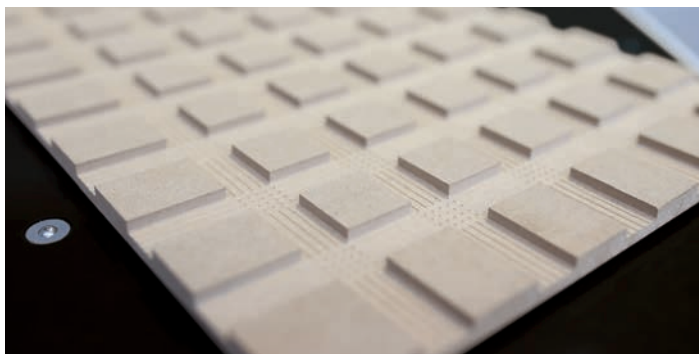

GROOVING EXECUTION

This device makes the beam saw even more flexible (opt.).



gabbiani p/pt automatic horizontal beam saws

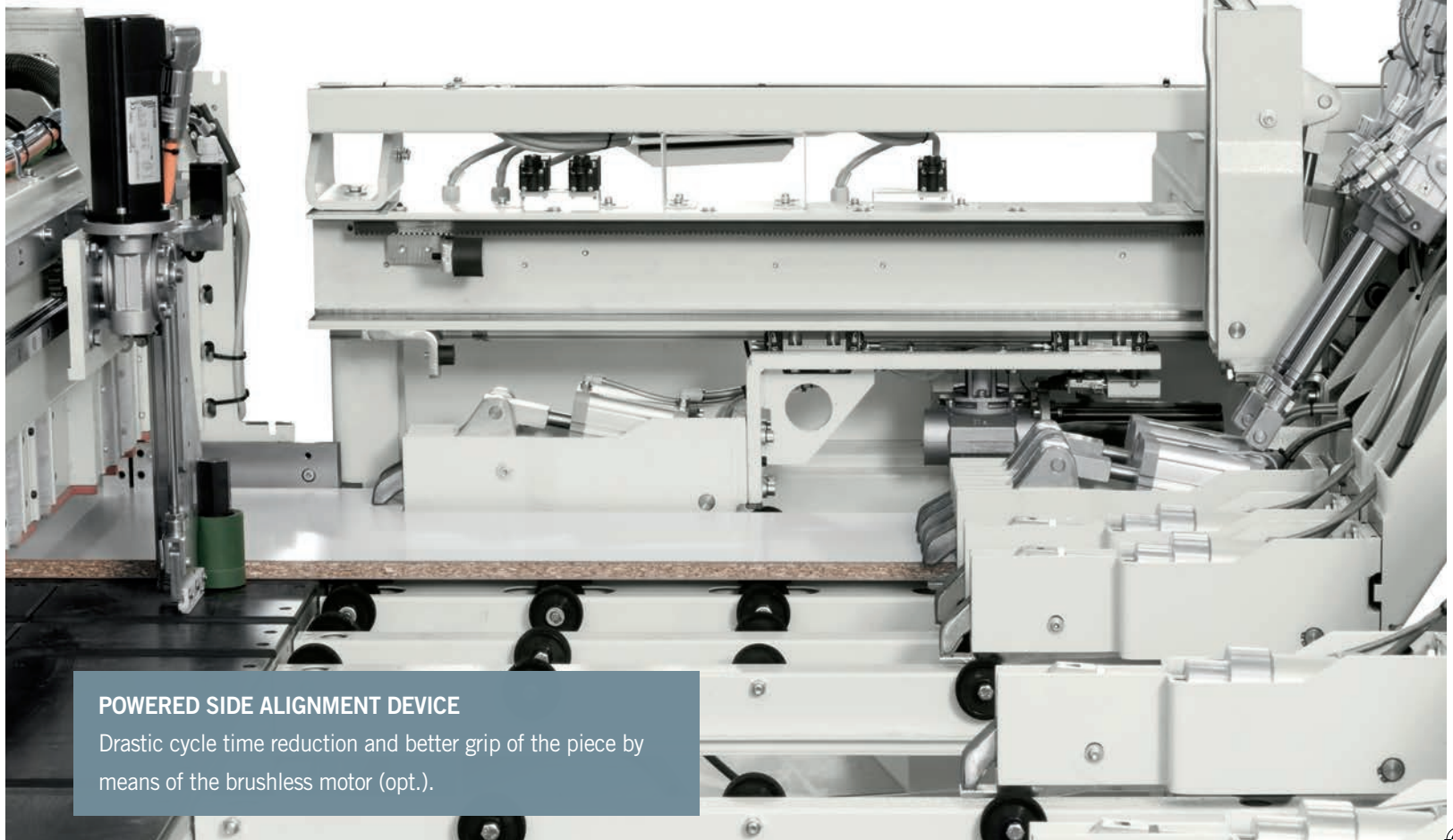

POWERED SIDE ALIGNMENT DEVICE

Drastic cycle time reduction and better grip of the piece by means of the brushless motor (opt.).



AUTOMATIC WORKPIECE MEASUREMENT: NO POSSIBILITY OF ERRORS

The device automatically detects both the panel size and its position on the work table avoiding difficult manual operations in case of very long panels and slowing down in the production cycle (opt.).



LOADING PLATFORM

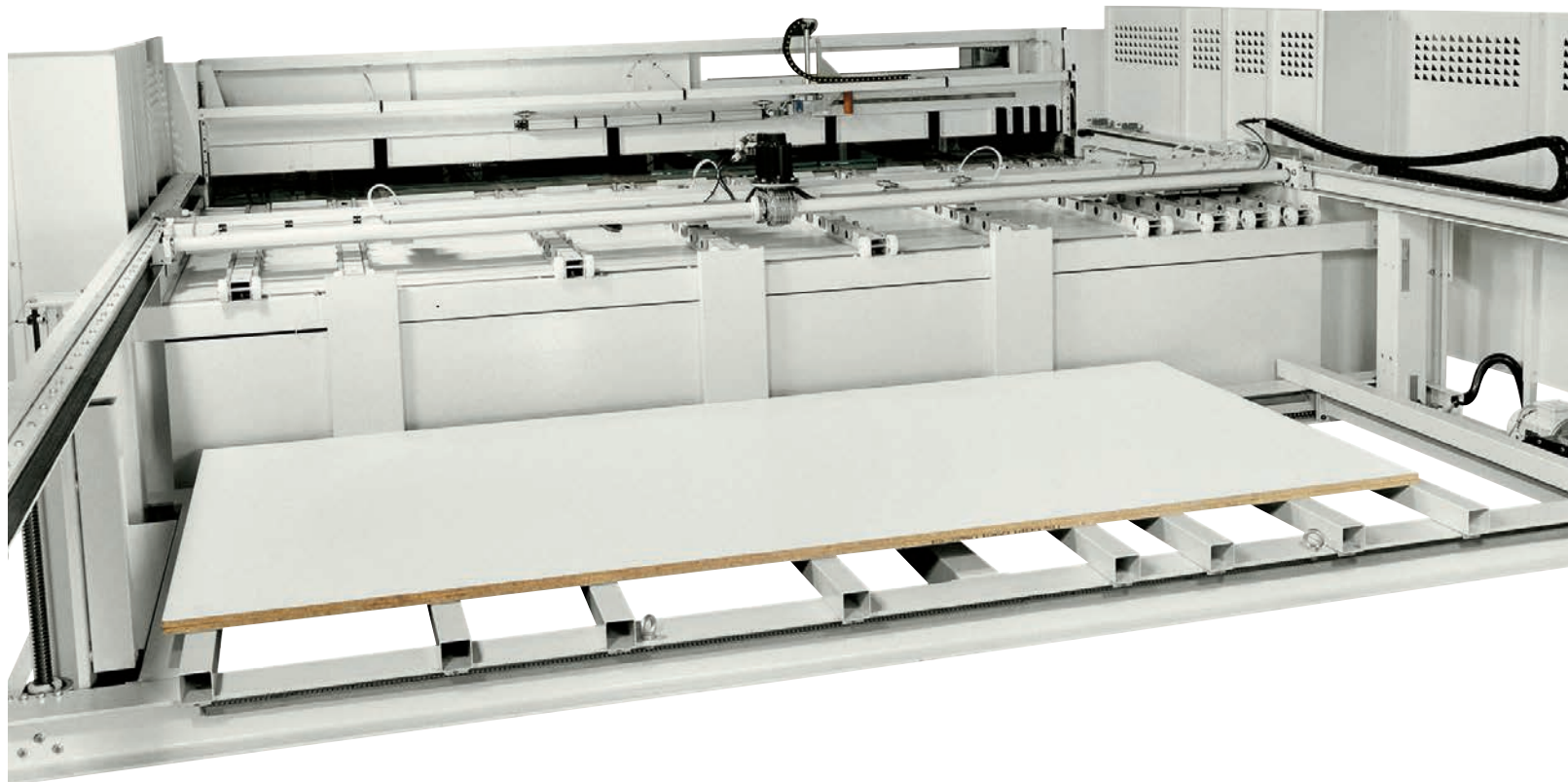

ALWAYS PARALLEL LIFTING OF THE PANELS STACKS

The lifting system running on 4 large trapezoidal screws (fig. 1) is able to maximize the load capacity (4000 kg), with any material and format, always ensuring maximum configuration with 3 access areas for panels loading /unloading and maximum combination of the panel stack height (600-800-1300 mm).

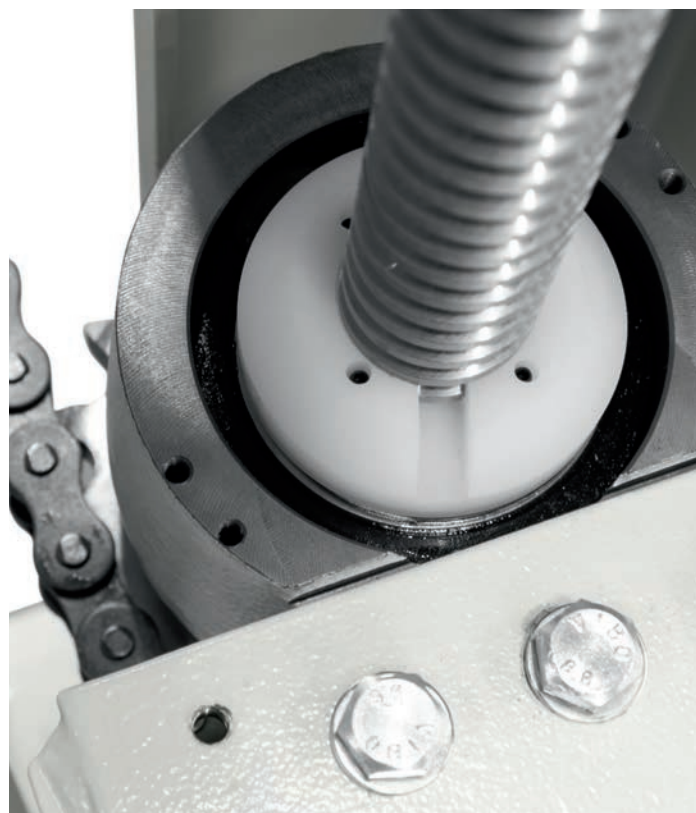

(fig. 1)

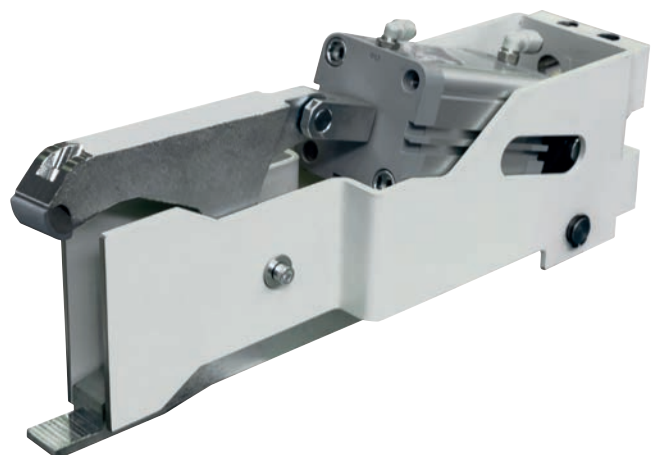

FLOATING CLAMPS: THE GUARANTEE OF THE END RESULT

The special shape of the clamps allows the loading and safe grip of panels at the maximum speed and perfect parallelism, even when panels are not perfectly planar.

OPTIMIZED SPACES WITH THE PRELOADING ROLLER CONVEYORS

One or more preloading roller conveyors allow the endless running of the saw. Loading and unloading systems of the “half stack” and the baseboard or pallet handling offer effective solutions to space and production needs.

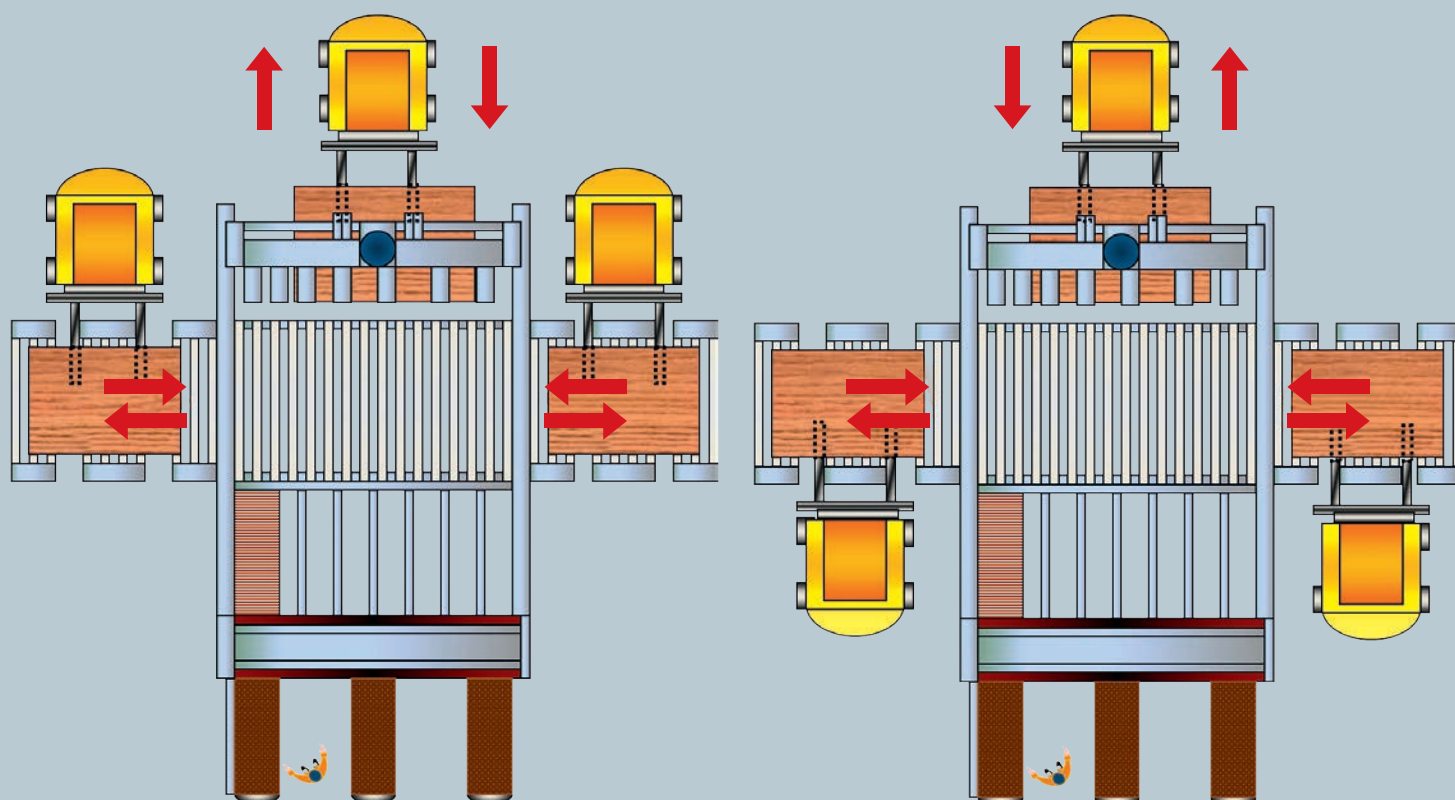

M Maestro Digital Systems

SMART SOFTWARE AND DIGITAL SERVICES TO ENHANCE PRODUCTIVITY OF WOODWORKING AND FURNITURE INDUSTRIES.

cutting lists



optimized cutting patterns

Maestro office

Office

Factory

Maestro active

optimized cutting patterns



cutting

SOFTWARE

Simple, smart and open.

Maestro software are tailored on the machine technology as well as on the entire process. All Maestro software share a common mission:

easy to use, so that any operator can easily and confidently learn and use the software;

smart, with algorithms and computing modules aiming at the best possible result;

open, in order to integrate existing software, and provide customer the coverage of all his process.

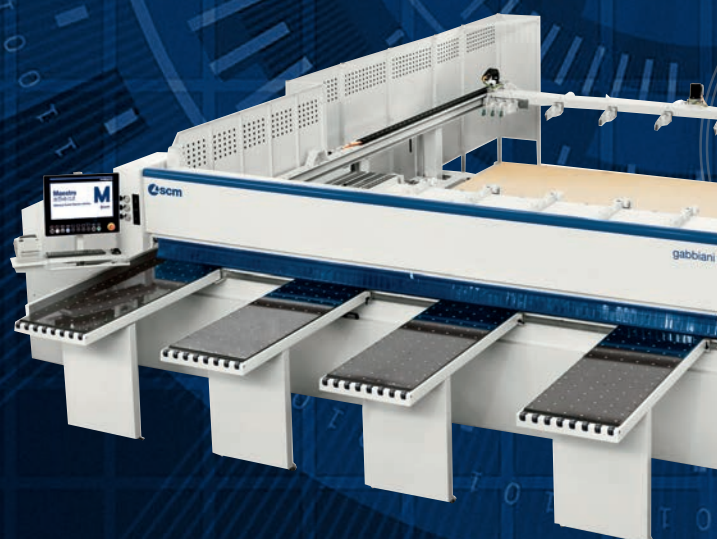

SCM accompanies woodworking companies throughout their whole process combining machines with matching software solutions and digital services, with a constant strive to enhance company productivity.

The software solutions powered by SCM are developed to optimize machine usage as well as the entire process, providing integration with the different software existing in the company.

DIGITAL SERVICES

Transforming the way it delivers services to its customers through digital technologies and particularly, the IoT platform that collects and analyses data coming from the machine, **SCM created a world of services enabled by Maestro connect.**

Meaning that connecting an SCM machine through Maestro connect will let customer subscribe a program of fast-evolving services and access a wide range of benefits that even go beyond the machine experience and will support and assist you through the whole life-cycle of your machine.





SCM LINEAR CUTTING OPTIMIZATION PROGRAM

In the office **Maestro optiwise** and **Maestro pattern office** provide support during the design and optimization phases. **Maestro pattern office** is the standard optimization program that can be used from the office for simple and efficient creation of cutting programs. **Maestro optiwise** is the linear cutting optimization program created for production management directly from the office. Depending on users' parameters, it automatically generates the cutting patterns, identifying the best solution among different results.



SOFTWARE

Office

TO EACH HIS OWN OPTIMIZATION SOFTWARE

Maestro pattern office is the standard optimization program for all SCM machines. **Maestro optiwise** is the professional software for controlling the entire costing and optimization process of the beam saw.

ADDITIONAL FUNCTIONS



Maestro pattern office

Maestro pattern office is the office version of the standard optimization program for all SCM machines. Maestro pattern office is the result of the integration between Maestro pattern - the standard optimization program on all SCM beam saws controls – and Maestro pattern import.



Maestro optiwise

Maestro optiwise is the professional software supplied by SCM for beam saws management. The main strengths are:

- Improved user experience: The user can easily and effectively carry out all raw material optimization operations.
- Increased efficiency: Improved user-experience enables required tasks to be performed in less time, increasing productivity
- Less effort for customization: the application is designed with a modular architecture that allows it to be easily adapted to each customer's production logic.
- Faster user learning: The application is a useful and simple tool that allows users to be productive in the shortest possible time.
- Multi-machine management: The application is able to manage optimizations and create machine programs for single-blade panel saws and angular systems.



Maestro converter cut

Maestro converter cut is the module that allows to integrate any type of cutting optimization programs with SCM beam saws through PTX file (minimum release 1.14).

Maestro active cut

Maestro active is the new operator interface software which has been unified across all SCM technologies. A single operator can easily and confidently run multiple machines due to controller and interface consistency: regardless the machine, Maestro active maintains the same look&feel, with many identical icons and navigation buttons, thus ensuring the same approach to interaction.

EASE OF USE

The new interface has been specifically designed and optimized for immediate use via touch screen. Graphics have been redesigned for simple and comfortable navigation, with tablet-like icons on touch screen controller.

"ZERO" ERRORS

Improved productivity thanks to integrated help and recovery procedures that reduce the possibility of error from the operator's side.

SOFTWARE

Factory

Maestro active cut

A REVOLUTIONARY APPROACH TO INTERACT WITH YOUR SCM MACHINE

FULL CONTROL OF PRODUCTION PERFORMANCES

The creation of customizable reports by operator, shift, program, forecast period (and much more) allows to monitor, optimize and improve the production performance.

FULL MACHINE AWARENESS AND KNOWLEDGE MANAGEMENT SYSTEM

Maestro active allows to record the times related to setup, maintenance, training and other events, tracing all the activities in a database. The operator's know-how is also stored and made available to other people inside the organization thanks to the possibility to comment and document all production events or notifications.

ORGANIZE YOUR PRODUCTION

Maestro active allows to create different users with different roles and authorizations (e.g.: operator, maintainer, administrator, ...). Any user can only execute the functions whose permissions have been assigned to him. It is also possible to define the work shifts on the machine and then detect activities, productivity and events that occurred in each shift.

OPTIMIZATION FUNCTION ON BOARD MACHINE

Maestro pattern is the linear cutting optimization program for user who wants to optimize cutting patterns with a few simple clicks.

SUPPLEMENTARY MODULES



Maestro pattern import

Maestro pattern import is the optional plug-in module which enables Maestro pattern importing production data directly from an MS Excel file.



Cut utility

Cuts editor for panels de-tensioning: software program that reduces tensions inside the material on longitudinal cuts; additional optimisation functions; off-cuts stock management: identification and automatic insertion of the off-cuts for a future use.



Cut editor

Labels printing software, panels editor, editor for Macro machining creation.



Cut manager

Simulator for cycle time calculation, simulated execution of the cutting diagrams of single or multi orders in 2D mode; priority-based and date-based scheduling of the order; advanced report.

A WORLD OF SERVICES FOR GREATER EFFICIENCY

Maestro connect

CONNECT YOUR MACHINE AND GAIN ACCESS TO A WORLD OF SERVICES

Connecting your machine through Maestro connect will let you subscribe a program of fast-evolving services. You will access a wide range of benefits that even go beyond the machine experience and will support and assist you through the whole life-cycle of your machine.

FASTER SERVICE INTERVENTION AND PROBLEM RESOLUTION

Maestro connect provides real time data and Health Records of the Machine also to SCM Service drastically reducing its troubleshooting time.

WORKING ALWAYS IN PERFECT CONDITIONS

Maestro connect can provide a full kit of sophisticated sensor devices to detect and warn the operator in case of alarming conditions of the machine.

DIGITAL SERVICES

SMART MAINTENANCE: DOWN TIME REDUCTION

Maestro connect reduces maintenance downtime thanks to:

- Automatic maintenance notifications and scheduling, to prevent failures and work in the best conditions of use;
- Direct connection to SCM Service thanks to an automatic ticket opening function.

SMART MACHINE: ANYTIME, ANYWHERE AWARENESS

Connecting your SCM machine also means having your machine always at hand.

Immediate instant notifications in case of alarms or downtimes allow customers to immediately take an action thus optimizing his productivity.

SMART MANAGEMENT: PRODUCTION PERFORMANCE OPTIMIZATION

Reports and KPIs allow further analysis thus increasing Customer Knowledge about his performance and results.

SMART PARTS: FAST PARTS REPLENISHMENT

Repairs are scheduled proactively since the system provides Spare Parts suggestions and a direct Integration with Smart Parts e-shop.

SMART LEARNING: EXECUTE WORK AND RECEIVE PROBLEM SOLVING SUPPORT

Maestro connect provides an intuitive Problem Solving Management System to help the operator to self solve any issue.

SMARTTECH: FASTER AUGMENTED SUPPORT

Maestro connect allows augmented reality support by means of Smarttech: the head-wearable computers with wireless connectivity that will bring the interaction between customer and SCM service to a higher level.

SMART WARRANTY: YOUR MACHINE ALWAYS IN PERFECT CONDITIONS

Together with scheduled maintenance contracts, you can take care of your asset by doubling the warranty from 1 year to 2 years* for complete peace of mind!

* *Please read the complete contract to understand terms and conditions.*

CONSOLE EYE-M

gabbiani p/pt
automatic horizontal beam saws

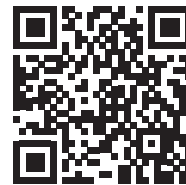

"console eye-M"
Video



scm 23

OPTIONAL DEVICES



ADDITIONAL CLAMPS

The clamps ensure a perfect panel stack hold-down at any pusher speed positioning.



LABEL PRINTER

Integrated in the machine control system, it allows the printing of labels which enables panel “identification” and to carry out all of the information required for any following processing (by edge banders, boring and routing machines, etc).



“HIGH SPEED” DEVICE: ABSOLUTE SPEED

Excellent cutting quality in reduced execution time: axes speed up to 120 m/min on the beam saw carriage and 70 m/min on the pusher. Optimized logic of cutting cycles on saw carriage, pressure beam and pusher units.

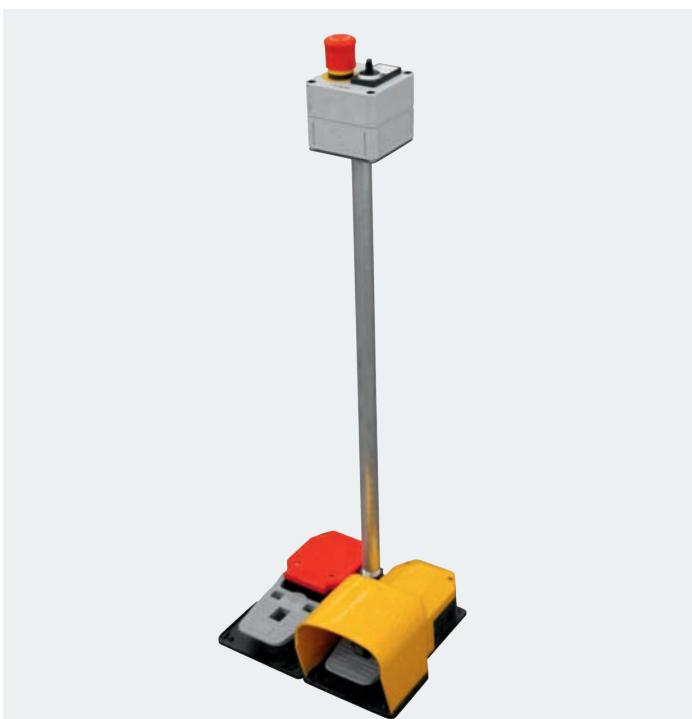

START-STOP CYCLE PEDAL

Simple and effective management of the cutting cycle even when large panels are on the front tables.



ELECTRICAL CABINET

with air conditioner which maintains the temperature at around 18°C.



TAILOR-MADE SOLUTIONS



FLEXSTORE ELR STORAGE FULLY INTEGRATED IN THE BEAM SAWS: OPTIMISING HAS NEVER BEEN SO EASY

flexstore elr is the SCM solution for the needs of companies making items to order with “just in-time” production: processing orders quickly, keeping costs down and high quality and productivity standards. flexstore elr is the automatic storage system which is able to serve beam saws, guaranteeing precision, high component quality and great reliability.

The excellent materials management permits high productivity and flexible machining.

Ensure:

- material savings thanks to management of material remaining after machining
- maximum flexibility for multi-function cells
- optimised material management in the production process: less space occupied, without compromising on efficiency
- reduced risk of damage to material thanks to the absence of sliding movements
- full traceability for batch 1 production with automatic labelling
- machines with integrated production process
- reduced order execution times



gabbiani p/pt
automatic horizontal beam saws

SECURE AND PRECISE PANELS TRANSFER.

The suction cup arm automatically adapts to the different lengths and widths of the panel to be picked up.



flexstore elr

scm

scm

OVERALL DIMENSIONS

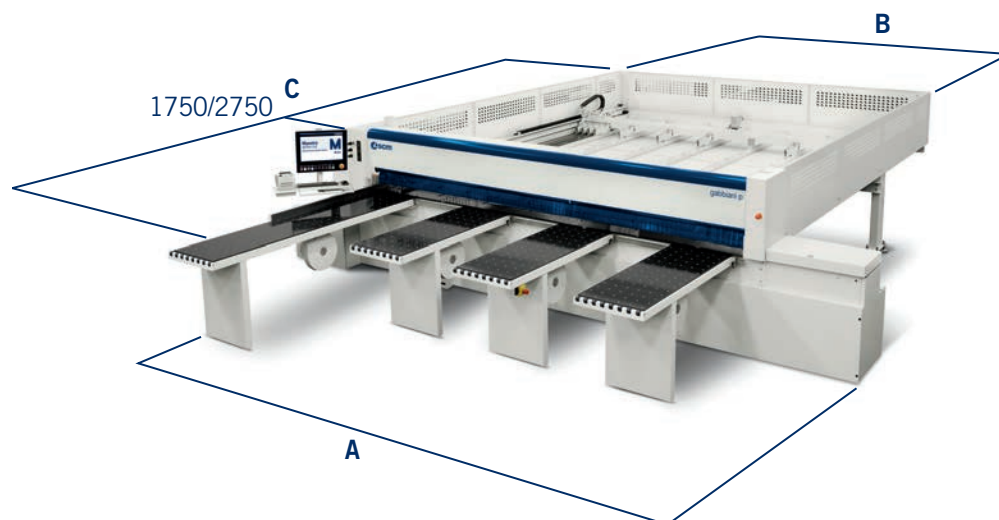

gabbiani p cutting dimensions	A	B	C
3300 x 2100	5400	3700	3200
3300 x 3200	5400	3700	4260
3800 x 3200	5900	4200	4260
3800 x 3800	5900	4200	4860
4300 x 3200	6400	4700	4260
4300 x 4300	6400	4700	5360

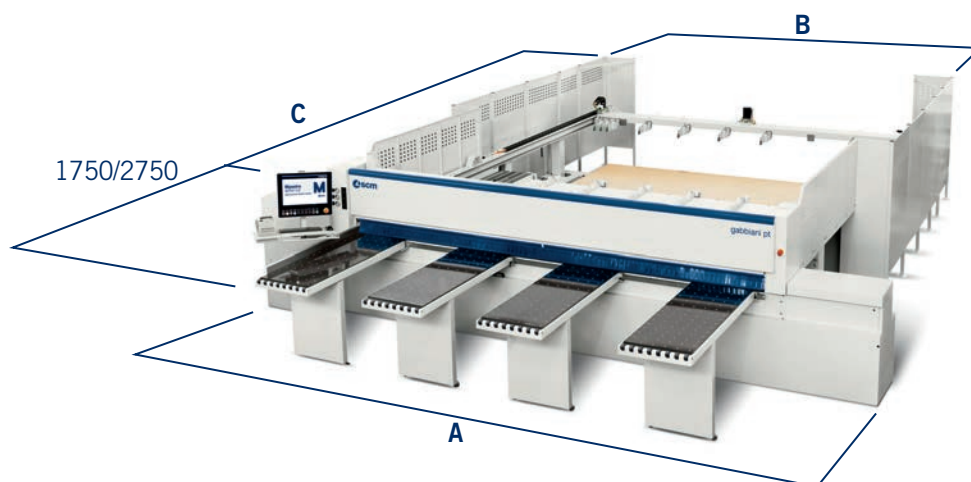

gabbiani pt cutting dimensions	A	B	C
3300 x 1850	5400	4450	6550
3300 x 2200	5400	4450	7100
3800 x 1850	5900	5000	6550
3800 x 2200	5900	5000	7100
4300 x 2200	6400	5450	7100

TECHNICAL DATA

gabbiani p/pt
automatic horizontal beam saws

gabbiani		p 60	p 80
Cutting length	mm	3300 - 3800 - 4300	
Blade projection	mm	60	80
Variable saw carriage speed (opt.)	m/min	6 - 60 (0 - 120)	
Variable pusher speed (opt.)	m/min	0 - 60 (0 - 70)	
Main blade motor S6-40% (opt.)	kW	7 (9)	7 (9 - 11)
Scoring blade motor 500 Hz	kW	1,3	
50 Hz Main blade/scoring blade rotating speed	g/min	4650/5850	
Main blade/scoring blade diameter	mm	300/200	340/200
Number of clamps	std	5	

gabbiani		pt 80	
Cutting length	mm	3300 - 3800 - 4300	
Cutting depth on platform	mm	1850 - 2200	
Max. panel stack height on loading platform with support beams	mm	600	
Blade projection	mm	80	
Variable saw carriage speed (opt.)	m/min	0 - 120	
Variable pusher speed (opt.)	m/min	0 - 70	
Main blade motor S6-40% (opt.)	kW	7 (9 - 11)	
Scoring blade motor 50 Hz	kW	1,3	
50 Hz Main blade/scoring blade rotating speed	g/min	4650/5850	
Main blade/scoring blade diameter	mm	340/200	
Number of clamps	std	5	



TELESOLVE

Remote service system to connect the machine's PC with the service department via Internet.



THE USE OF POWER ONLY WHEN IT IS REQUIRED

SavEnergy allows making things operate only when they are really necessary. It means the machine automatically enters "stand-by" mode when there are no panels to be machined.

**COMPANY WITH
QUALITY SYSTEM
CERTIFIED BY DNV
= ISO 9001 =**

The technical data can vary according to the requested machine composition. In this catalogue, machines are shown with options. The company reserves the right to modify technical specifications without prior notice; the modifications do not influence the safety foreseen by the CE Norms.

Maximum noise levels measured according to the operating conditions established by EN 1870-13:2012
Acoustic pressure in process 83 dbA (measured according to EN ISO 11202:2010, uncertainty K = 4 dB)
Acoustic power in process 99 dbA (measured according to EN ISO 3746:2010, uncertainty K = 4 dB)
Even if there is a correlation between above mentioned "conventional" noise emission values and average levels of personal exposure of operators over eight hours, these last also depend on the real operating conditions, duration of exposure, acoustic conditions of the working environment and presence of further noise sources, this means the number of machines and other adjacent processes.

WE'LL GO THE EXTRA MILE FOR YOU



SERVICE AND MAINTENANCE



TRAINING SERVICE



SPARE PARTS



DIGITAL SERVICES

SCM OFFERS A FULL RANGE OF **HIGHLY SPECIALISED SERVICES** WITH A QUALITY AND RELIABILITY THAT STEM FROM 70 YEARS OF EXPERIENCE IN THE INDUSTRY.

From installation and production start-up to services and maintenance. From training to the supply of specific original spare parts: **we provide solutions designed around you!**



SERVICE AND MAINTENANCE

- Remote support
- Scheduled maintenance contracts
- Warranty extension



TRAINING SERVICE

- Courses for machine operators
- Software and programming courses
- Training in production start-up



SPARE PARTS

- Recommended spare parts list
- E-shop
- Interactive spare-parts catalogues
- Repairs on electronic parts, glue tanks and electro-spindles



DIGITAL SERVICES

- Maestro Connect - IoT platform to be constantly connected with your machines
- Smartech - assistance with augmented reality
- My Scm portal - opening of service ticket and single point of access to the apps and Services tools

CONTACT

SCM SERVICE

via Emilia 77 - 47921 Rimini - Italy
tel. +39 0541 700100
scmservice@scmgroup.com
www.scmwood.com

SCM SPAREPARTS

Via Emilia, 61 - 47921 - Rimini - Italy
tel. +39 0541 674111
spareparts@scmgroup.com
www.scmwood.com



My Scm

THE STRONGEST WOOD TECHNOLOGIES ARE IN OUR DNA

SCM. A HERITAGE OF SKILLS IN A UNIQUE BRAND

70 years of success gives SCM the centre stage in woodworking technology. This heritage results from bringing together the best know-how in machining and systems for wood-based manufacturing. SCM is present all over the world, brought to you by the widest distribution network in the industry.

70 years history

3 main production sites in Italy

300.000 square metres of production space

20.000 machines manufactured per year

90% export

20 foreign branches

400 agents and dealers

500 support technicians

500 registered patents

In SCM's DNA also strength and solidity of a great Group. The SCM Group is a world leader, manufacturing industrial equipment and components for machining the widest range of materials.

SCM GROUP, A HIGHLY SKILLED TEAM EXPERT IN INDUSTRIAL MACHINES AND COMPONENTS

INDUSTRIAL MACHINERY

Stand-alone machines, integrated systems and services dedicated to processing a wide range of materials.



WOODWORKING TECHNOLOGIES



TECHNOLOGIES FOR PROCESSING COMPOSITE MATERIALS, ALUMINIUM, PLASTIC, GLASS, STONE, METAL

INDUSTRIAL COMPONENTS

Technological components for the Group's machines and systems, for those of third-parties and the machinery industry.



SPINDLES AND TECHNOLOGICAL COMPONENTS



ELECTRIC PANELS



METALWORK



CAST IRON



is more



REV. N. 03 - 03.2023



SCM GROUP SPA
via Casale 450 - 47826 Villa Verucchio, Rimini - Italy
tel. +39 0541 674111 - fax +39 0541 674274
gabbiani@scmgroup.com
www.scmwood.com



00L0528805G

