



**salvamac**  
G R O U P

**FRIEND\_300**

**LEADER\_50/60/70**

**FLIXCUT\_SERIE**



**salvamac\_selection**



# salvamac selection salvamac selection

**One service  
more, one  
problem less.**

We select for you some products that marry the culture and philosophy of our company, with the aim of facilitating and optimizing your work. Our network and its strength allow us to introduce periodically some new products dedicated to the solid

wood industry, all at an affordable price. We move ourselves following a clear strategy: to offer simple-to-use machines and a complete range of accessories and tools to make easy the reducing your costs and increasing your profits.

***Un servizio in più,  
un pensiero in  
meno.***

*Selezioniamo per te alcuni prodotti che sposano la cultura e la filosofia della nostra azienda, con l'obiettivo di facilitare e ottimizzare il tuo lavoro. Il nostro network e la sua forza ci permettono di introdurre periodicamente nuovi prodotti dedicati*

*all'industria del legno massiccio, tutti ad un prezzo accessibile. Ci muoviamo seguendo una chiara strategia: offrire macchine semplici da usare e una gamma completa di complementi e strumenti con i quali sia facile ridurre i costi e aumentare i vostri profitti.*

# The key points



## Consulting

We help you to understand which products are most suitable for your business.

## Consulenza

*Ti aiutiamo a capire quali sono i prodotti più adatti alla tua attività..*



## Quality

High quality is the first requirement to guarantee reliability and safety.

## Qualità

*L'alta qualità è il primo requisito per garantire affidabilità e sicurezza.*



## Completeness

These products complete the instrumentation useful to optimize your work.

## Completezza

*Questi prodotti completano la strumentazione utile ad ottimizzare il tuo lavoro.*

# I punti chiave



## FRIEND\_300

Friend\_300 is the true friend for every operator able to act as help, support and solution of daily handling problems. The Salvamac 's professional height-adjustable multifunction table allows you to operate in maximum safety, reducing the efforts of the operators and carrying out work tasks with the maximum efficiency typical of lean production.

It can also be customized to the individual needs of each customer.

*Friend\_300 è il vero amico per ogni operatore in grado di fungere da aiuto, supporto e soluzione dei problemi quotidiani di movimentazione. Il tavolo multifunzione professionale regolabile in altezza di Salvamac permette infatti di operare in massima sicurezza, riducendo gli sforzi degli operatori e di svolgere le mansioni lavorative con la massima efficienza tipica della lean production.*

*Può essere inoltre personalizzato in base alle esigenze individuali di ogni cliente.*



	<b>FRIEND_300</b>
Working height max/min <i>Altezza di lavoro</i>	1000/500 mm
Upper frame perimetre <i>Perimetro telaio superiore</i>	1140 x 650 mm
Workload max <i>Carico max</i>	300 kg
Wheels <i>Ruote con freno per blocco</i>	4
Foot hydraulic pump <i>Cilindro idraulico</i>	1
Color <i>Colore</i>	Ral 1007
Upper worktop not included <i>Piano superiore di lavoro non inclusa</i>	Customizable <i>Personalizzabile</i>

- ▶ Really solid, reinforced and robust steel structure
- ▶ Exclusive designed Hydraulic Cylinder for high performance
- ▶ Mobile with big diameter wheels and parking brake

- ▶ Ergonomic and professional design
- ▶ High reliability and quality of the components

- ▶ *Struttura in acciaio davvero solida, rinforzata e robusta*
- ▶ *Esclusivo cilindro idraulico per prestazioni elevate*
- ▶ *Mobile con ruote di grande diametro e freno di stazionamento*

- ▶ *Design ergonomico e professionale*
- ▶ *Elevata affidabilità e qualità dei componenti*



# LEADER

The high level of quality and the real heavy-duty structures make of Salvamac's briquetting presses a leader for the recycling and compression of wood and industrial waste. Thanks to their design, construction and features our briquetting presses are widely known for their efficiency and reliability.

A wide range of accessories is also available to customize the machine to every client's individual needs.

*L'alto livello di qualità e le strutture veramente robuste fanno delle bricchettatrici Salvamac un leader per il riciclaggio e la compressione del legno e dei rifiuti industriali. Grazie al loro design, costruzione e caratteristiche le nostre bricchettatrici sono ampiamente conosciute per la loro efficienza e affidabilità.*

*È inoltre disponibile un'ampia gamma di accessori per personalizzare le macchine in base alle esigenze individuali di ogni cliente.*



	<b>LEADER_50</b>	<b>LEADER_60</b>	<b>LEADER_70</b>
Loading bin motor <i>Motore di carico</i>	1,5 + 0,75 kW	1,5 + 0,75 kW	1,5 + 0,75 kW
Press auxiliary motor <i>Motore pressa ausiliario</i>	4 kW	7,5 kW	11 kW
Hourly throughput <i>Produzione oraria</i>	30 - 50 kg/h	50 - 70 kg/h	70 - 100 kg/h
Briquette diameter (Ø) <i>Diametro bricchetto (Ø)</i>	50 mm	60 mm	70 mm
Length of the briquettes <i>Lunghezza dei bricchetti</i>	da 30 a 50 mm	da 30 a 50 mm	da 30 a 50 mm
Dimensions <i>Dimensioni macchina</i>	1250 x 1940 x 1470 mm	1250 x 1940 x 1470 mm	1250 x 1940 x 1470 mm
Weight <i>Peso macchina</i>	960 Kg	1270 Kg	1600 Kg

- ▶ Load-bearing base frame for loading bin H900 mm
- ▶ Oil tank for hydraulic control unit
- ▶ Hopper with loading worm screw
- ▶ Mechanical press with die head located beside the loading bin

- ▶ Hydraulic unit comprising solenoid valves, gear pumps, plates and hydraulic circuit tubes
- ▶ PLC control panel. Power supply of machine with three-phase line 380V-50Hz

- ▶ *Telaio di base portante il minisilo Ø900 H900 mm*
- ▶ *Serbatoio dell'olio della centrale oleodinamica*
- ▶ *Tramoggia con coclea di carico*
- ▶ *Meccanica pressa con testata ed estrusore, posta a fianco del minisilo*

- ▶ *Unità oleodinamica costituita da elettrovalvole, pompe ad ingranaggi, piastre e tubi*
- ▶ *Quadro elettrico di comando con PLC, con possibilità di controllore*



# FLIXCUT

The FlixCut series represents Salvamac's entry level solution for cutting wood. Thanks to their design, construction and the high level of component quality, our radial saws are widely known for their efficiency and reliability.

A wide range of accessories is also available to customize the machines according to the individual needs of each customer.

- ▶ Hard steel structure.
- ▶ High precision in cutting thanks to the solid and stable head unit.
- ▶ Articulated arm and head-unit for diagonal cuts, inclined cuts and trimming.
- ▶ Montage and installation are fast and really easy.

*La serie FlixCut rappresenta la soluzione entry level della Salvamac per il taglio del legno. Grazie al loro design, costruzione e l'alto livello di qualità dei componenti le nostre seghe radiali sono ampiamente conosciute per la loro efficienza e affidabilità.*

*È inoltre disponibile un'ampia gamma di accessori per personalizzare le macchine in base alle esigenze individuali di ogni cliente.*

- ▶ *Solida struttura in acciaio.*
- ▶ *Elevata precisione nel taglio grazie alla testata solida e stabile.*
- ▶ *Un unico braccio snodato e testata per tagli diagonali, tagli inclinati e rifilature.*
- ▶ *Montaggio e installazione sono veloci e veramente facili.*



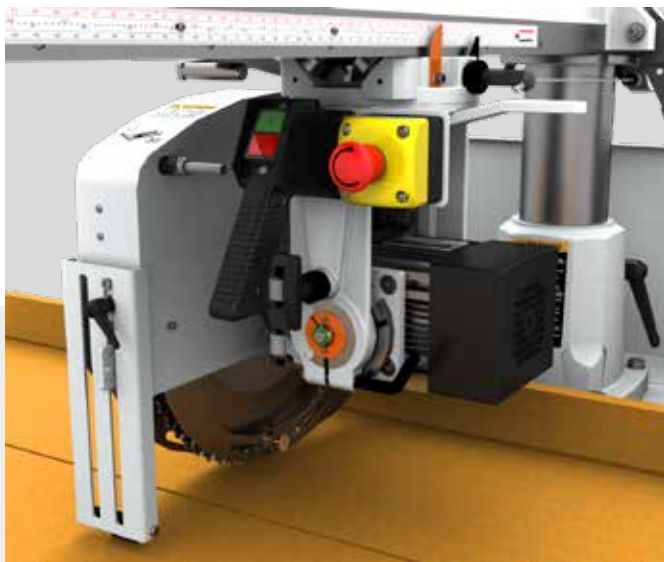

	<b>FLIXCUT_640</b>	<b>FLIXCUT_960SUPER</b>
Motor power <i>Potenza motore</i>	3 kW (4 HP)	5,5 kW (7,5 HP)
Blade diameter (not included) <i>Diametro lama (non inclusa)</i>	400 mm	565 mm
Max cutting height <i>Massima altezza taglio</i>	125 mm	200 mm
Max cutting width <i>Massima larghezza taglio</i>	545 x 20 mm	850 x 20 mm
Min cutting width <i>Minima larghezza taglio</i>	450 x 125 mm	680 x 200 mm
N Carriage bearings <i>N cuscinetti carro</i>	8	8

**Prodotti solidi,  
professionali  
e affidabili per  
ottimizzare il tuo  
lavoro**

***Prodotti solidi,  
professionali  
e affidabili per  
ottimizzare il tuo  
lavoro***

cross cutting



CLASSIC\_40/50/60



SALVAPUSH\_2000



SALVASTOP\_100

# air&painting



**TROLLEY**



**SUPERDEP**



**COMPACT\_ECO**



**COMPACT\_PLUS**



**ARTIST DRY**



**4 YOU**

# selection



**FRIEND\_300**



**LEADER\_50/60/70**



**FLIXCUT\_640/960/960 SUPER**



**SALVAMAC SP. Z O.O.**  
ul. Modrzewiowa 18,  
62 081 Przeźmierowo  
POLAND

**IDEAS FACTORY**  
Via XX Settembre 105  
31015 Conegliano TV  
ITALY

**[info@salvamac.com](mailto:info@salvamac.com)**  
**[www.salvamac.com](http://www.salvamac.com)**